

BALCONGLAS FALCE-70B

PROFILO FERMAVETRO BASSO H 64 MM / CLAMPING PROFILE H 64 MM / KLEMMPROFIL H 64 MM

• Sistema a pannelli mobili in vetro, impacchettabili senza la baia di parcheggio, con guida a terra, con profili anta con fori nel vetro.

• Slide and turn system, with floor channel and without parking bay, panels with holes in the glass.

• Schiebe-Dreh-System mit beweglichen Glasmodulen, mit Glasbohrungen, mit Bodenführung und ohne Parkraum.

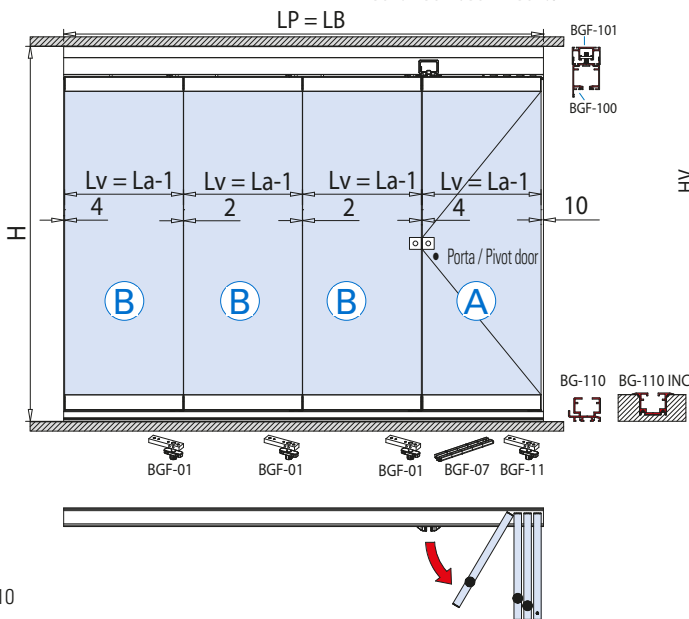
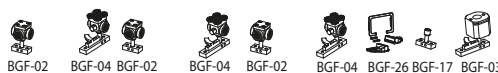
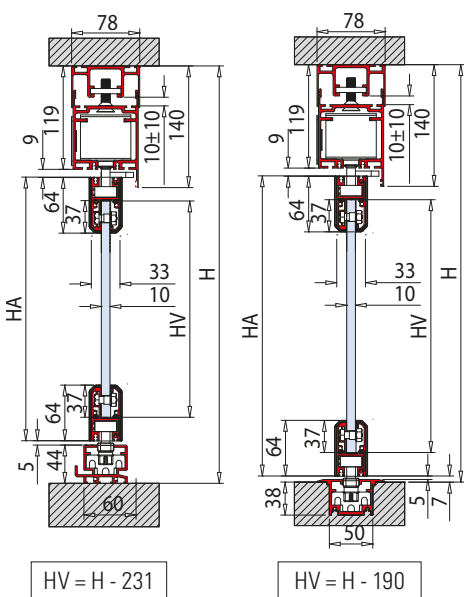
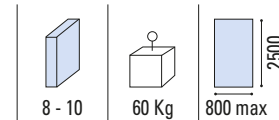

LAVORAZIONE VETRO
GLASS PREPARATION
GLASBEARBEITUNG

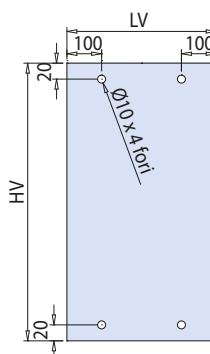

SISTEMI BALCONGLAS
BALCONGLAS SYSTEMS

- Canalina incassata BGM-110
- Recessed floor profile BGM-110
- Versenkte Bodenschiene BGM-110

- Indicare sempre il verso di apertura e lo spessore vetro
- Please specify always opening direction and glass thickness
- Bitte immer Öffnungsrichtung und Glasdicke angeben

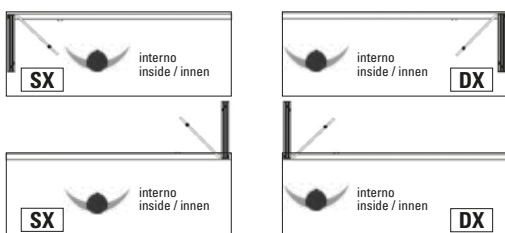

- (A)**
 - Porta laterale
 - Pivot door
 - Seitentür
- (B)**
 - Anta intermedia scorrevole
 - Intermediate folding panel
 - Mittiges Faltelement

BGF-B-SET 2 (LB MAX = 2000 mm)	(A)(B)
BGF-B-SET 3 (LB MAX = 3000 mm)	(A)(B)(B)
BGF-B-SET 4 (LB MAX = 4000 mm)	(A)(B)(B)(B)
BGF-B-SET 5 (LB MAX = 5000 mm)	(A)(B)(B)(B)(B)
BGF-B-SET 6 (LB MAX = 6000 mm)	(A)(B)(B)(B)(B)(B)
BGF-B-SET 7 (LB MAX = 6000 mm)	(A)(B)(B)(B)(B)(B)(B)