

Balcony FROM 2026

- Sistema a pannelli mobili in vetro con guida a terra, impacchettabili senza la baia di parcheggio, con profilo a incollaggio senza fori nel vetro.
- Slide and turn system with bottom guide and without parking bay, panels to be glued without holes in the glass.
- Schiebe-Dreh-System mit beweglichen Glasmodulen, mit Bodenführung und ohne Parkraum, Glas zur Verklebend ohne Glasbohrungen.

PATENT
PENDING



OUTDOOR

BALCONY-1000

- Con incollaggio del vetro
- Glass to be glued
- Glas zum Verklebend

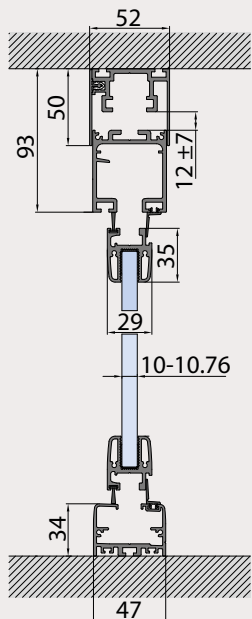

xme716





P825



F3753



- VERSIONE LINEARE
- LINEAR VERSION
- LINEARE VERSION



- VERSIONE AD ANGOLO CON IMPACCHETTAMENTO TUTTO DA UN LATO
- CORNER VERSION WITH STACKING ON ONE SIDE
- ECKVERSION MIT PARKBEREICH AUF EINER SEITE



OUTDOOR

10-10,76 45 Kg min 450 max 750 2200

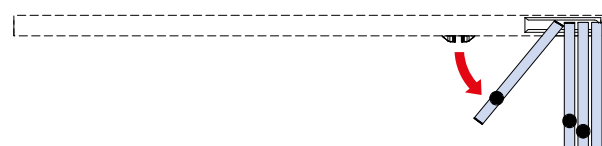

1. REGOLAZIONE DINAMICA - DYNAMIC ADJUSTMENT - DYNAMISCHE EINSTELLUNG

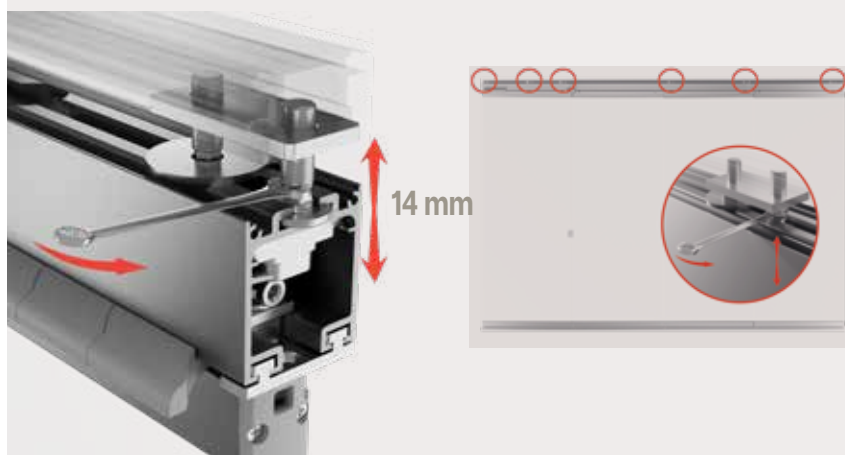

- Regola frontalmente, nella massima comodità, spostando il punto di regolazione dove vuoi ed in qualsiasi momento (anche ad installazione avvenuta) per ottenere la massima efficienza nell'allineamento delle ante.
- Adjust from the front with maximum convenience by moving the adjustment point wherever and whenever you want (even after installation) to achieve optimal panel alignment.
- Komfortable Fronteinstellung durch freie Platzierung des Einstellpunkts – jederzeit und auch nach der Montage – für höchste Effizienz bei der Flügelausrichtung.

2. SISTEMA FALCE - HOOK SYSTEM - HAKENSYSTEM



- Il nostro brevetto che vincola immediatamente le ante dopo una minima rotazione. Grazie ad un nuovo upgrade sulla geometria degli elementi, abbiamo migliorato l'efficienza in fase di apertura e impacchettamento.
- Our patented system locks the panels immediately after minimal rotation. Thanks to an upgrade in the geometry of the components, we've improved the efficiency of opening and stacking.
- Unser Patent verriegelt die Flügel sofort nach einer minimalen Drehung. Mit dem neuen Upgrade der Geometrie haben wir die Effizienz beim Öffnen und parken weiter verbessert.

3. CARRELLO - CARRIAGE - LAUFWAGEN

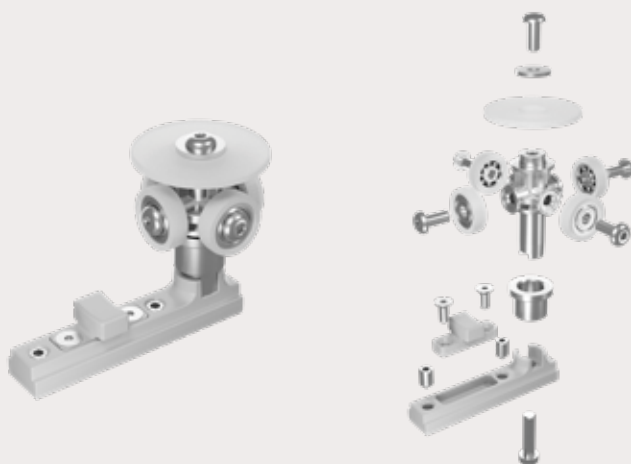

- Insieme alla falce gli elementi che ci contraddistinguono: corpo in Zama e 4 ruote, con diametri maggiorati, per uno scorrimento fluido e unico per questo tipo di prodotto.
- Together with the hook, our distinctive features include a zamak body and 4 oversized wheels for smooth and unique sliding performance in this product category.
- Zusammen mit dem Haken sind dies unsere Erkennungsmerkmale: Zamak-Gehäuse und 4 Räder mit vergrößertem Durchmesser für einen besonders flüssigen Lauf – einzigartig in dieser Produktklasse.

4. MANUTENZIONE - MAINTENANCE - WARTUNG



- Manutenzione ed ispezione senza perdite di tempo e senza fatica, grazie alla possibilità di estrarre l'anta interessata direttamente dalla maschera di uscita senza la necessità di smontare l'intero sistema.
- *Quick and effortless maintenance and inspection thanks to the ability to remove the relevant panel directly from the exit guide without disassembling the entire system.*
- *Wartung und Inspektion schnell und einfach – die betroffene Flügel kann direkt aus dem Austrittsmodul entnommen werden, ohne das gesamte System zu demontieren.*

5. PROFILO ANTA - PANEL PROFILE - FLÜGELPROFIL



- Profilo anta minimale ad incollaggio con guarnizione antivento e antinfiltrazione.
- *Minimal panel profile to be glued, with windproof and watertight gasket.*
- *Minimalistisches Flügelprofil zum Verkleben mit wind- und wasserdichter Dichtung.*

6. CONFIGURAZIONI AD ANGOLO - CORNER CONFIGURATIONS - WINKELKONFIGURATIONEN



- Il nuovo carrello ad 4 ruote scorre liberamente in qualsiasi direzione con fluidità senza eguali.
- *The new 4-wheel carriage slides freely in any direction with unmatched smoothness.*
- *Der neue 4-Rollen-Laufwagen bewegt sich frei und außergewöhnlich geschmeidig in alle Richtungen.*

7. TAPPI LATERALI - ENDCAPS ENDKAPPEN



- Tappi laterali sagomati per chiusura totale degli spazi tra i profili.
- *Shaped endcaps for total closure of spaces between profiles.*
- *Geformte Endkappen für einen vollständigen Abschluss zwischen den Profilen.*

8. CHIUSURA - CLOSURE VERSCHLUSS

**PATENT
PENDING**



- Nuovo catenacciolo di chiusura con astina invisibile.
- *New locking bolt with invisible rod.*
- *Neuer Verschlussbolzen mit unsichtbarer Stange.*



- Nuovo catenacciolo di chiusura con serraggio e astina invisibile.
- *New locking bolt with closing system and invisible rod.*
- *Neuer Riegelschloss mit Schließsystem und unsichtbarer Stange.*

PARAPETTO CON Balcony FROM 2026

- Chiusura completa in vetro per balconi.
- Complete glass enclosure for balconies.
- Komplettverglasung für Balkone.

OUTDOOR





P825



F3753



BALCONY+
BALAUSTRÀ STRIPE, FISSAGGIO A PAVIMENTO
RAILING SYSTEM STRIPE, FLOOR INSTALLATION
STRIPE-GELÄNDER, BODENMONTAGE



BALCONY +
BALAUSTRÀ STRIPE FISSAGGIO LATERALE
RAILING SYSTEM STRIPE, SIDE INSTALLATION
STRIPE-GELÄNDER, SEITENMONTAGE



BALCONY +
BALAUSTRÀ
FRAMELESS RAILING SYSTEM
GANZGLASGELÄNDER



OUTDOOR

Balcony + STRIPE FISSAGGIO A PAVIMENTO FROM 2026

BALCONY + STRIPE, FLOOR INSTALLATION

BALCONY + STRIPE, BODEN MONTAGE

- Chiusura completa in vetro per balconi composta da ringhiera Stripe fissaggio a pavimento con sistema ad impacchettamento Balcony integrato.
- Complete glass enclosure for balconies consisting of a Stripe railing with floor-mounted fixing and integrated Balcony slide and turn system.
- Komplettverglasung für Balkone, bestehend aus einem Stripe-Geländer mit Bodenbefestigung und integriertem Balcony Schiebe-Dreh-System.

OUTDOOR



Balcony + STRIPE FISSAGGIO LATERALE FROM 2026

BALCONY + STRIPE, SIDE INSTALLATION

BALCONY + STRIPE, SEITEN MONTAGE

- Chiusura completa in vetro per balconi composta da ringhiera Stripe fissaggio laterale con sistema ad impacchettamento Balcony integrato.
- Complete glass enclosure for balconies consisting of a Stripe railing with side-mounted fixing and integrated Balcony slide and turn system.
- Komplettverglasung für Balkone, bestehend aus einem Stripe-Geländer mit seitlicher Befestigung und integriertem Balcony Schiebe-Dreh-System.

OUTDOOR



Panoramica prodotto
Product overview



P825

Listino
Price list



F3753



OUTDOOR

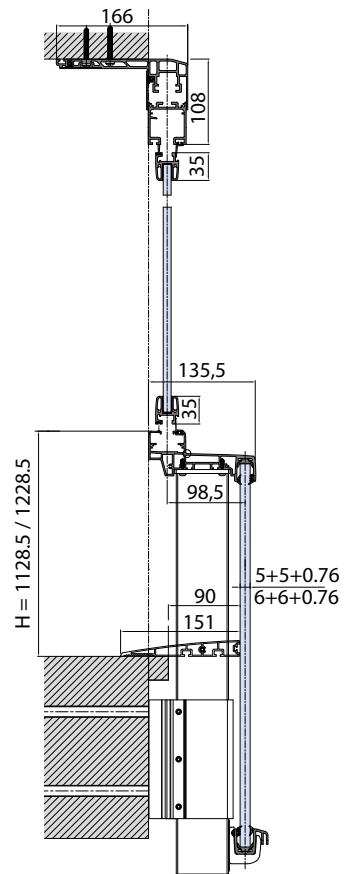

Balcony + BALAUSTR FROM 2026

BALCONY + FRAMELESS GLASS RAILING

BALCONY + GANZGLASGELÄNDER

- Chiusura completa in vetro per balconi composta da parapetto con profilo a pavimento e sistema ad impacchettamento Balcony integrato.
- Complete glass enclosure for balconies consisting of a railing system with floor-profile mounting and integrated Balcony slide and turn system.
- Komplettverglasung für Balkone, bestehend aus einem Ganzglasgeländer mit Bodenprofilmontage und integriertem Balcony Schiebe-Dreh-System.

OUTDOOR



Panoramica prodotto
Product overview



P825

Listino
Price list



F3753

